

TOKISTAR Trillium



TOKISTAR LIGHTING



Trillium™

Tokistar's Trillium uses Tri-Color LEDs to produce vibrant color from a single RGB light source. Trillium creates perfectly blended color whether the LED is viewed directly, casting light on a reflective surface, or used to backlight translucent material.

Trillium LED modules are tightly sealed in an all-environment package and approved for use in wet-location settings. Our control systems are easy to program and operate, adding to the system's overall economy and appeal.



This application is one example of how Trillium color can be controlled. Each "block" of color is assigned to a different channel of a DMX control system.

Contents

[Introduction](#) | 2 - 3

[How to Specify](#) | 4

[Specifications / Mounting](#) | 5

[System Layout / LED Drivers](#) | 6

[Controllers / Dimmer Packs](#) | 7



Cover:
Trillium adds colorful accents to the registration desk at Planet Hollywood in Las Vegas.



Trillium's dynamic color capability is on full display at this storefront.



LEDs installed in Trillium Channel provide a perfectly linear effect of color-changing light.



Trillium Channel conceals all wiring for a refined look.



Trillium™



Trillium's flexibility and compact profile are ideal for outlining complex shapes in tight spaces. Color is easily changed or animated to complement any environment or theme.

Trillium operates efficiently at 8VDC. This lower voltage produces very little heat and adds to the system's reliability. Trillium is cool to the touch and can be specified for applications where it may be subject to direct contact.

Basic System

Trillium's most flexible form is available in LED module spacings of 2", 4", 6" and 12" on center.

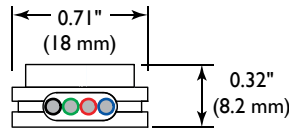
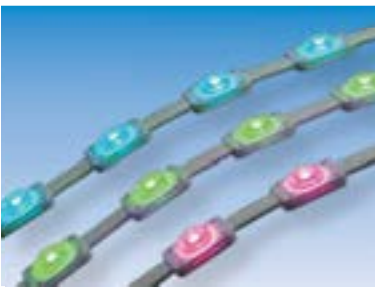

TRI - 50 - RGB

LED Spacing		RGB-LEDs
Code	Spacing	Watts/Volts Per LED
50	2" (50 mm)	0.32 W / 8VDC
100	4" (100 mm)	
150	6" (150 mm)	
300	12" (300 mm)	

Trillium Channel

A satin aluminum channel is available for straight runs. Custom finishes are available on request.

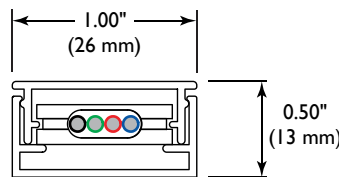
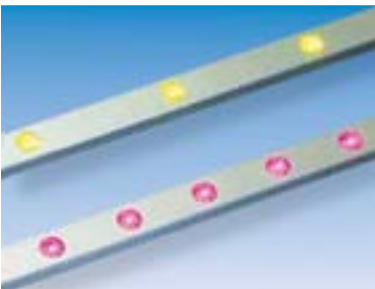

TRI - CH - 100 - RGB

LED Spacing		RGB-LEDs
Code	Spacing	Watts/Volts Per LED
100	4" (100 mm)	0.32 W / 8VDC
150	6" (150 mm)	
300	12" (300 mm)	



Specifications

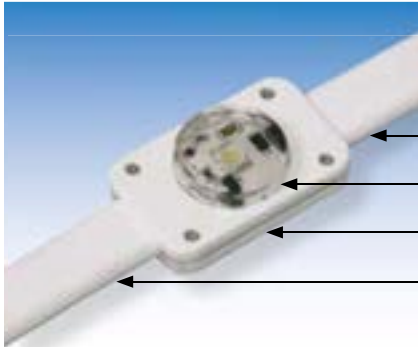

All plastic components are resistant to Ultraviolet Light in accordance with standard UL 746C.



Wet-Location Listed



This product is protected under U.S. and Foreign Patents.

Flexible Conductors are #20 AWG

Light Sources are 0.32 Watt/8VDC LEDs

LED Modules are permanently sealed to cable

Insulation is flexible PVC with flammability rating UL 94V-0

Accessories

Trillium can be surface mounted to structures using our mounting track, panel fasteners or clamps.

Mounting Track

Part #: TRI-MT

LED modules snap into a semi-rigid track. The track is fastened with screws, hi-bond adhesive tape or construction adhesive.

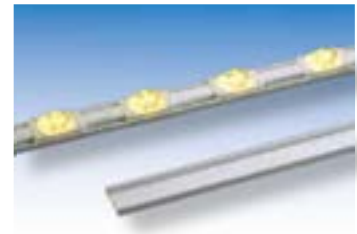
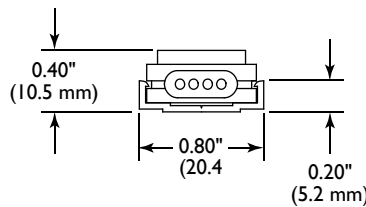

Panel Fasteners

Part #: TRI-PF

Trillium is easily incorporated into display panels and signs with our panel fasteners. The LED module is inserted from behind, concealing all wiring.

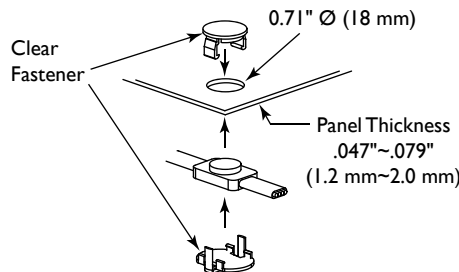

Mounting Clamps

Part #: TRI-MC

For maximum flexibility, Trillium can be attached with clamps. Each clamp is fastened with a screw concealed behind the fixture.

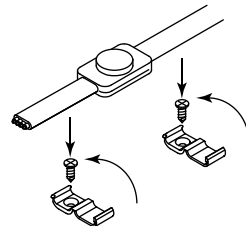

End Caps

Part #: TRI-CH-ECL

Feed End Cap

Part #: TRI-CH-EC

Dead End Cap

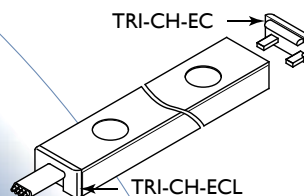



System Overview

A Trillium Lighting System includes four components:

- 1) Lighting Fixtures with Tri-Color RGB LEDs
- 2) LED Drivers to convert an AC input into an 8VDC output
- 3) Lighting Controllers to store program data and communicate it to Dimmer Packs
- 4) Dimmer Packs to accept data from the Lighting Controller and power the lighting fixtures at 0-8VDC

In accordance with Class 2 guidelines, Trillium fixtures and the secondary circuits they are connected to must not exceed 40 Watts (125 LED modules @ 0.32 Watts). To minimize voltage drop and ensure all LED modules are producing a similar level of colored light, do not exceed the maximum run lengths shown in this chart.

Trillium is Wet-Location Listed when operated from our LED Drivers.



Maximum Run Lengths	
LED Spacing	Length
2" (50 mm)	20' 10" (6.25 M)
4" (100 mm)	41' 8" (12.5 M)
6" (150 mm)	50' (15 M)
12" (300 mm)	70' (21 M)

LED Drivers

LDR8-40

Tokistar's LDR8-40 is a 40 Watt UL Recognized Class 2 LED Driver used to convert an AC input into an 8VDC output. It may be operated from a wide range of input voltages. The enclosure is suitable for wet locations.

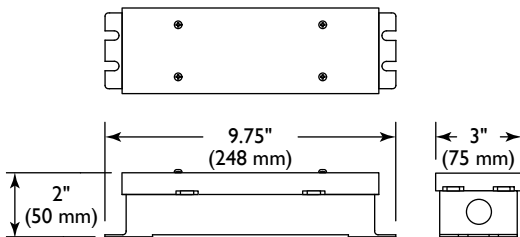

Specifications

Input Range: 100-240 VAC
 Frequency Range: 50/60 Hz
 Output: 8VDC (Adjustable +10% / -25%)
 Max. Output Current: 5.0A
 Max. Output Power: 40W
 Protection: Overload, Overcurrent, Short Circuit
 Operating Temperature: -30°C to +60°C

Mechanical Specifications

Dimensions: 3" x 9.75" x 2"
 Weight: 1.94 lbs
 Enclosure Rating: Nema 3/IP65
 Mounting: Flange Mount
 Connection: Knockouts for 1/2" Conduit

Compliance/Safety

UL 1310 Class 2
 CAN/CSA 22.2#9
 EN60950

LED Capacity

0.32 Watt LEDs: 125 pieces

LDR8-80

Tokistar's LDR8-80 is a dual output Class 2 LED Driver with two independent 40 Watt outputs. It may also be operated from a wide range of input voltages. The enclosure is suitable for wet locations.

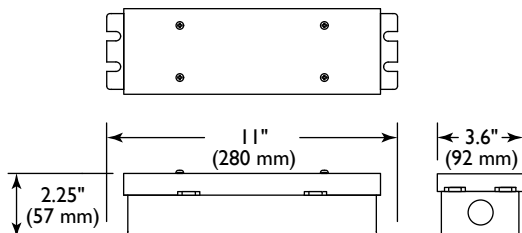

Specifications

Input Range: 100~240 VAC
 Frequency Range: 50/60 Hz
 Output: 8VDC (Adjustable +5% / -30%)
 Max. Output Current: 10.0A (2 @ 5.0A)
 Max. Output Power: 80W (2 @ 40W)
 Protection: Overload, Overcurrent, Short Circuit
 Operating Temperature: -30°C to +60°C

Mechanical Specifications

Dimensions: 3.6" x 11" x 2.25"
 Weight: 4 lbs
 Enclosure Rating: Nema 3/IP65
 Mounting: Flange Mount
 Connection: Knockouts for 1/2" Conduit

Compliance/Safety

UL 1310 Class 2
 CAN/CSA 22.2#9
 EN60950

LED Capacity

0.32 Watt LEDs: 250 pieces

Lighting Controllers

Color Mix System

Our economical Color Mix System is capable of being operated on demand. Each dimmer pack operates up to 125 LED modules. CAT5 cable with RJ45 connectors on each end link the components together. Up to 25 dimmer packs may be connected in series if the total length of all CAT5 cable does not exceed 165 feet from the LC-3CH-CM control station to the last dimmer pack. CAT5 cables are included with units.

Color Mix features include:

- Cross-Fading, Fading, Flashing and Demo Mode
- Ten memory locations to mix and store your favorite color selections
- Six animation patterns which cycle between favorite color selections
- Rotary dials for precise color mixing/speed-rate adjustment
- Adjustable fading/flashing rate
- Control station includes color-changing LED indicator



Part #: LC-3CH-CM

The Control Station is provided with a 50 foot CAT5 cable. Power to this unit comes from the LED Driver powering the first dimmer pack. The unit installs in a double-gang junction box.



Part #: LC-3CH-DP

Each dimmer pack is provided with a CAT5 cable and capable of operating up to 125 LED modules (40 Watts maximum). Dimensions: 1-1/2" x 3-1/2" x 4-1/16"

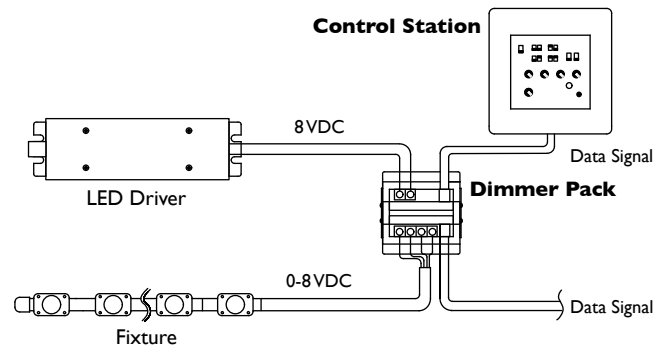

Dual output LED drivers require a dimmer pack for each output.

DMX Dimming System

DMX Dimmer Packs are capable of operating up to 125 each 0.32 watt LEDs (40 Watts maximum). Dimmer Packs are addressable, and may be used with any controller working on DMX protocol.



Part #: LC-3CH-DMX

Max. Load: 40 Watts @ 8VDC
 Environmental Rating: Dry Location/IP20
 Dimensions: 3/4" x 1-3/4" x 3-1/2"
 Weight: 50g / 0.11 lbs
 Listing: ETL Listed/CE Certified
 Operating Temperature: 0~+50°C

Up to 36 Dimmer Packs can be linked together with Data Cable. For applications exceeding 36 Dimmer Packs, a Splitter is required. Splitters can operate an unlimited number of Dimmer Packs. Consult factory for details on Splitters.

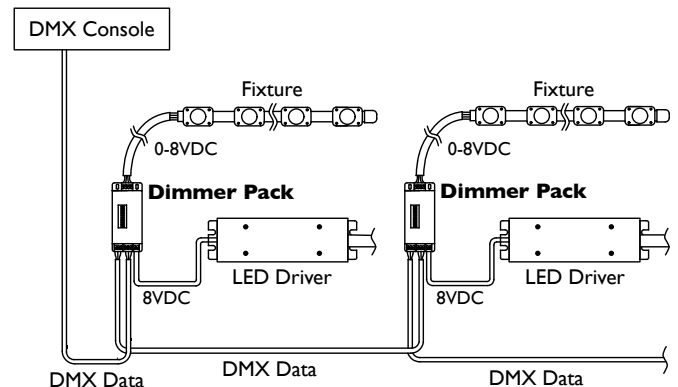

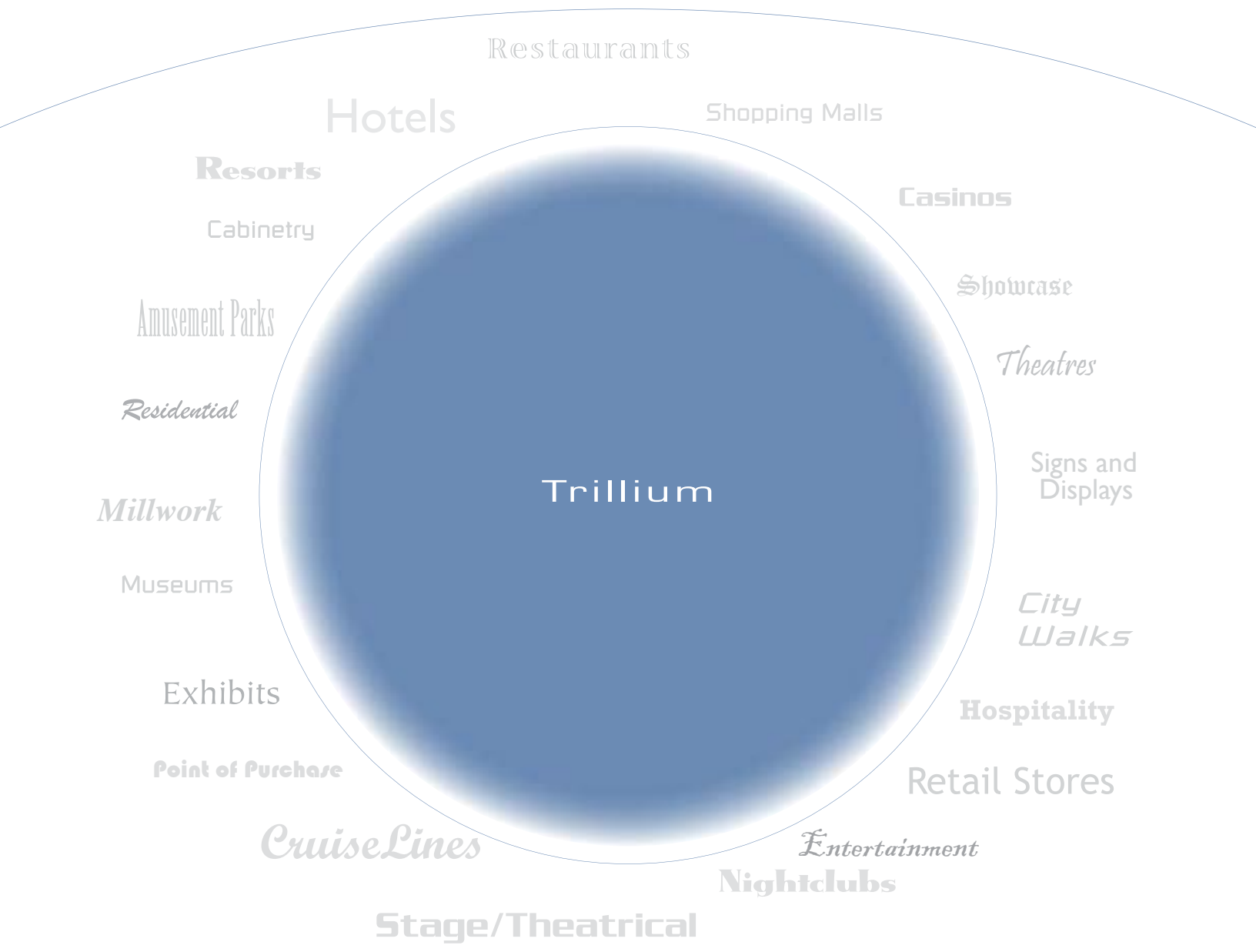

TOKISTAR® LIGHTING INC.

1015 E. Discovery Lane • Anaheim, CA 92801

Tel: 714.772.7005 • Fax: 714.772.7014 • Toll free in USA: 877.340.7633
 Email: info@tokistar.com • Website: www.tokistar.com